



## RT-100 Inline Refractive Index / %Glycol / %BRIX

### **Product Description**

The PRISM RT-100 is an inline digital refractometer that measures the refractive index of a liquid sample & provides a direct reading of highly accurate concentration values for a wide variety of water and process related applications. It is a stand-alone device capable of self-sustained operation, live data display and data logging. The PRISM RT-100 offers fully integrated 4–20mA and RS-485 Modbus output signals for connectivity to any microprocessor, display, PLC or DCS network.

The PRISM RT-100 has built-in temperature dependent equations to convert the measured sample temperature and refractive index to the percentage concentrations of Mono-Ethylene Glycol (MEG), Mono-Propylene Glycol (MPG), Sugar Content (BRIX) and Advanced Low Viscosity Fluid (ALV). Additional concentration curves may be added in the future by Pyxis Lab® - as the market demands.

The PRISM RT-100 is a very robust, digital sensor and is capable of operating in contaminated fluid samples. It is important, however, to note that users should take all precautions to mitigate and filter suspended solids from the sample stream prior to the sensor. This is to avoid tenacious deposit build-up on the sensor eye. In highly fouled applications, Pyxis Lab® recommends users conduct sensor eye cleaning on a regular basis per manual guidelines. Pyxis Lab® is also developing an automated sensor cleaning accessory for installation into the Sanitary Fitting Tri-Clamp Flow Cell assembly, as an optional accessory in the near future. The materials of the PRISM RT-100 and Sanitary Tri-Clamp Flow Assembly consist of 316L stainless steel, neoprene and sapphire and are compliant with FDA-21 CFR177.2600 for inline sanitation in food and beverage process applications.

### **Typical Applications**

- Refractive Index Direct Read for Process Applications
- Mono-Ethylene Glycol Closed Loop System Monitoring
- Mono-Propylene Glycol Closed Loop System Monitoring
- Brix/Sugar Concentration Process Applications
- Advanced Low Viscosity Fluid Heat Transfer Fluid
- Specific Gravity Determination via Refractive Index



Contact Us at [info@pyxis-lab.com](mailto:info@pyxis-lab.com) for More Information...

## Features

- 4–20mA Output of Sample Temperature & the unit of Display, Selected via the Screen Interface
- User Customizable 4–20mA Concentration Output Ranges with our uPyxis® app
- RS-485 Modbus RTU Output of Temperature, Refractive Index and other Diagnosis Parameters
- Built-In Temperature Dependent Equations %BRIX, %MPG, %MEG and %ALV
- Future Addition of Product Concentration Curves by Pyxis Lab® - as market requests
- Local Display & Push-Button Interface
- Optional 110VAC–240VDC Wall Outlet Powered for Independent Operation without a Controller
- Built-In Historical Data Log up to 56 Days of Storage at 1 Reading per Minute via uPyxis®
- Bluetooth® Enabled when used with the MA-CR Bluetooth® Adapter
- Sturdy 316L Stainless Steel Tri-Clamp Flow Cell Assembly with 3/4inch NPT Flange
- Easy Installation & Removal for Cleaning & Maintenance - No Tools Needed

## Specifications

Item	PRISM RT-100
Part Number	55105
Refractive Index Range	1.30000–1.5100
BRIX Range	0.00–85.00%
ALV, MPG & MEG Range	0.00–100.00%
Temperature Range	-20–80 °C
Resolutions	Refractive Index: ±0.0001   BRIX & Glycol: ±0.1%
Accuracy	Refractive Index: ±0.0002   BRIX & Glycol: ±0.2%
Sample Temperature	-4–158 °F (-20–70 °C)
Max Sample Pressure/Flow	≤142psi (0.98 MPa) / <13.5 GPM (9.8ft/s)
Environmental Temperature	14–104 ° F (-10–40 °C)
Weight	6.2lbs (2.8kg)
Dimension	4.33 x 4.57 inch (110 x 116 mm)
Light Source	LED
Wet Materials	Sapphire, 316L Stainless Steel
Signal Output/Power	(2) 4–20mA & RS-485 Modbus / 24VDC (1.5W)
Protection/Regulation	IP-67 / CE & RoHS Marked

## **RT-100 PRISM Package (P/N: 55105) Includes**

- (1) PRISM RT-100 Refractive Index Sensor
- (1) 8-Pin Female Cable
- (1) 316L Stainless Steel Tri-Clamp Flow Cell Assembly (P/N: 56206)
- (1) MA-1.5CR Cable (1.5m / 4.9ft 8-Pin Male Adapter & Flying Lead) (P/N: 50746)

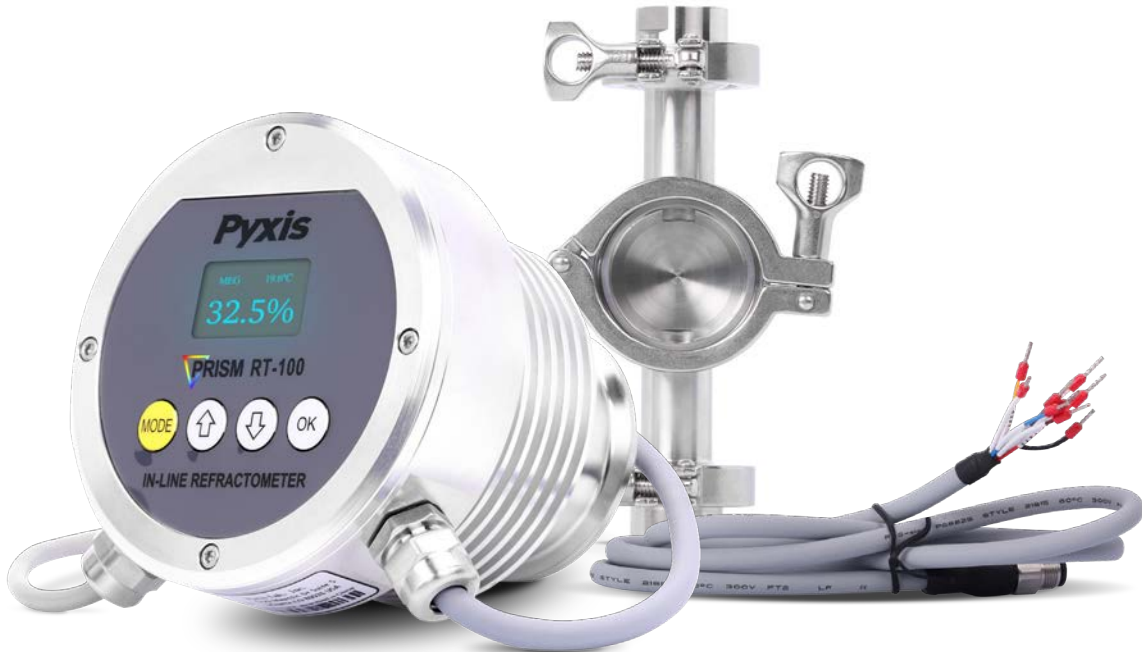

## **Optional Accessories - Purchased Separately**

<b>Part Number</b>	<b>Accessory</b>
56207	Wall Outlet Power Supply Adapter - Plug In Power
MA-CR	MA-CR Bluetooth® Adapter for uPyxis®
MA-NEB	MA-NEB USB Bluetooth® Adapter for uPyxis®
50743	MA-50CR - 50ft 8-Pin Extension Cable
SER-01	Sensor Cleaning Kit
56206	Tri-Clamp Flow Cell Assembly - Full Replacement
56209	Tr-Clamp Flow Cell Replacement Gasket Kit



## Sensor Dimensions (mm)

Unit: mm

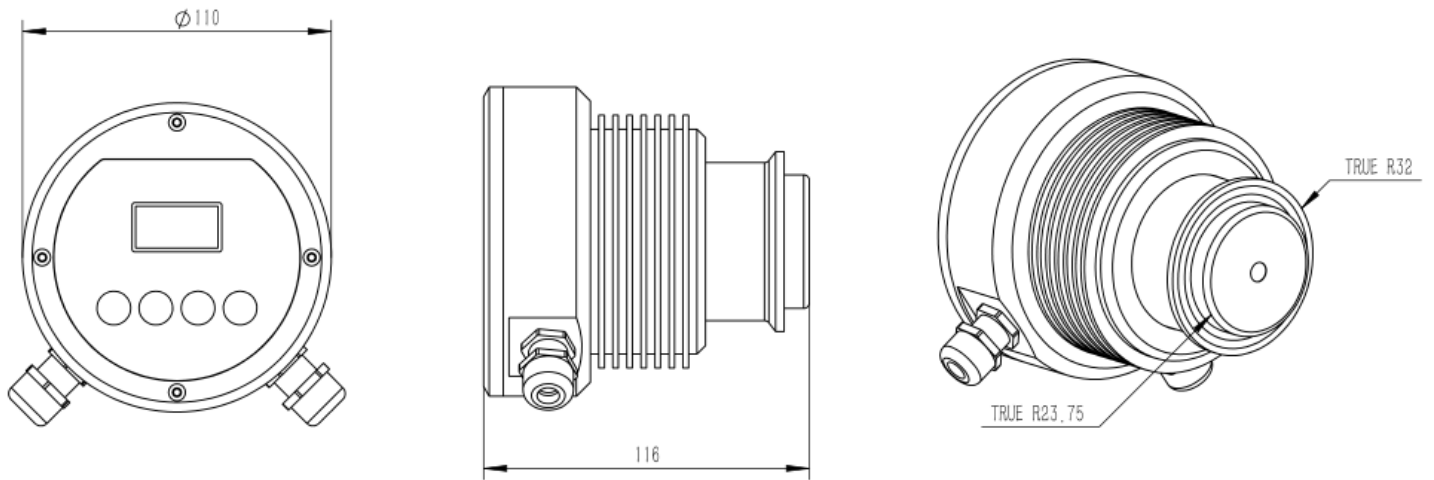

## Flow Assembly Dimensions (mm)

Unit: mm

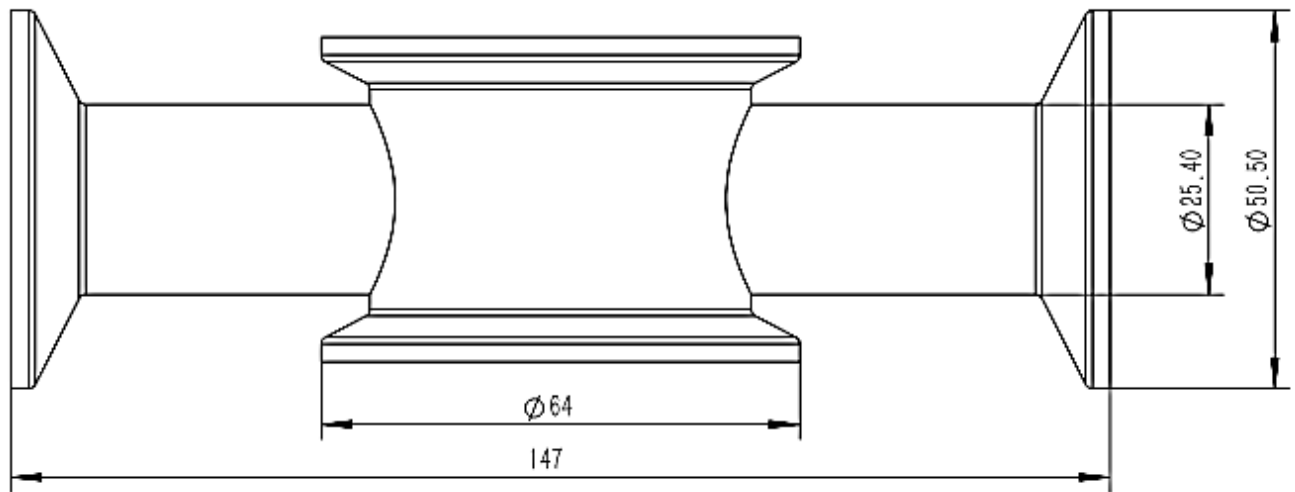

**RT-100 Tri-Clamp Flow Cell Components (Included with each RT-100 Purchase)**

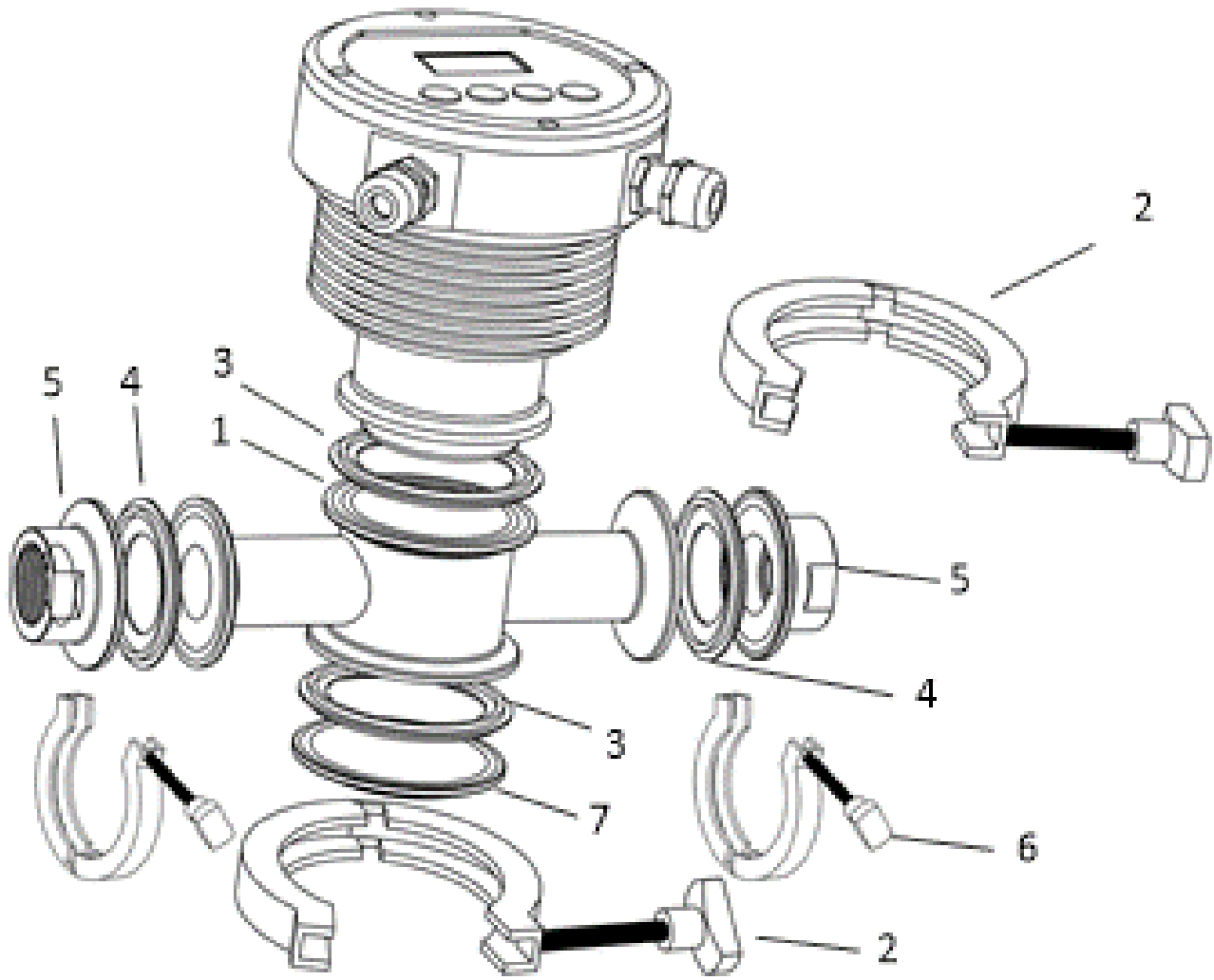

ID #	Description
1	Flow Cell with 2.5in Port for PRISM Sensor Head
2	Sensor Tri-Clamp 2.5in
3, 4, 8	Tri-Clamp Flow Cell Gasket Kit (P/N: 56209)
5	3/4inch FNPT Flange
6	Flange Tri-Clamp 2in
7	Plug Cap 64mm, Reserved Self-Cleaning

## Order Information

## Part Number

RT-100 PRISM Inline Refractometer	55105
Wall Outlet Power Supply Adapter Kit	56207
MA-CR Bluetooth® Adapter	MA-CR
MA-NEB USB Bluetooth® Adapter	MA-NEB
MA-50CR 50ft Extension Cable with 8-Pin Adapters	50743
Sensor Cleaning Kit	SER-01
Tri-Clamp Flow Cell Assembly - Full Replacement	56206
Tri-Clamp Flow Cell Assembly Replacement Gasket Kit	56209

### ***uPyxis® Diagnosis, Calibration & Historical Data Transfer***

The uPyxis® app manages all Pyxis Lab® portable meter and inline sensors on mobile and desktop devices. When connected to the PRISM RT-100, the uPyxis® app enables users to diagnose, air-calibrate Refractive Index Value, Off-Set Calibrate Liquid Concentrations to Refractive Index Value, Restore Factory Settings, Transfer Historically Logged Data and View Live Sensor Refractive Index & Temperature Data Trends.

For wireless access to the RT-100, the MA-CR Bluetooth® Adapter will be REQUIRED and should be purchased as an optional accessory.

#### **NOTE:**

The uPyxis® mobile app is evolving rapidly and users can find the latest version at no cost on the Apple iStore or GooglePlay. The desktop version of the uPyxis® app can be downloaded at:

**[www.pyxis-lab.com/upyxis-app](http://www.pyxis-lab.com/upyxis-app)**

